

**NEC**

*Xen*



digital  
telephone  
user guide

**axis**  
**master**

## Xen Digital Telephones

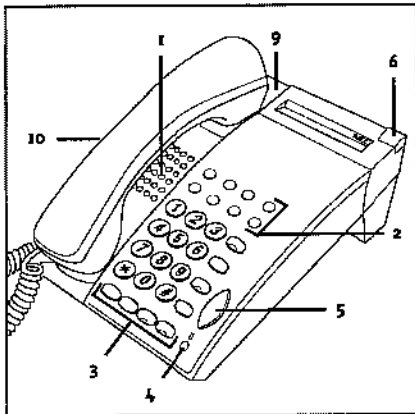

**Xen Talk 8 line non display**

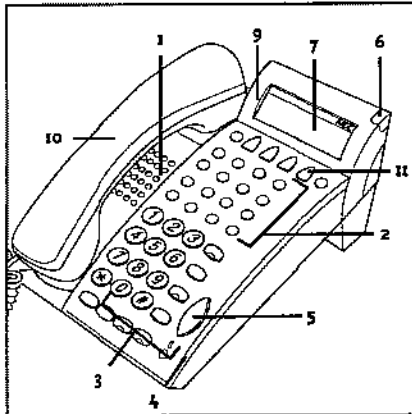

**Xen Exec 16 line display**

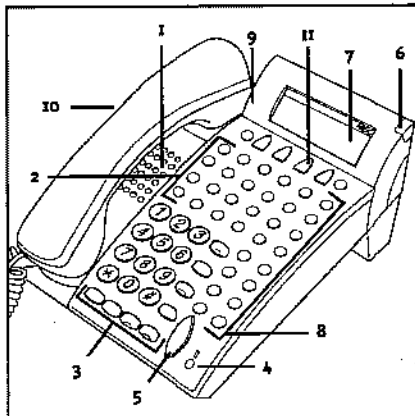

**Xen Professional 16 line display  
with 16 DSS/BLF One Touch Keys**

1. Speaker
2. Line Keys/Feature Access Keys
3. Dial pad/Dedicated Function Keys
4. Microphone and Microphone LED
5. Volume Control
6. Large LED (360° Visual Ring Indicator)
7. Alphanumeric Display
8. One Touch Keys
9. Hookswitch
10. Built-in Headset Jack
11. Soft Keys



## Table of Contents

General Information  
Answering Calls

Pages 2 & 3

Making Calls  
Microphone Control  
Handsfree Calls  
Placing a call on Hold

Pages 4 - 5

Transferring Calls  
Conference  
Call Park - System  
Station Busy/No Answer Options

Pages 6 - 7

Outside Call Dialling Options

Pages 8 - 9

Call Pickup  
Paging  
Background Music  
Call Forwarding

Pages 10 - 11

Call Forwarding Destination  
Customised Message  
Station Outgoing Lockout  
Account Code Entry  
Account Code Forced/Verified

Pages 12 - 13

DISA Password  
ACD/UCD  
Volume Control  
Programming

Pages 14 - 15

Feature Access Keys  
One Touch Keys  
Character Entry Codes

Pages 16 - 17

Quick Entry Guide  
Quick Reference Guide

Pages 18 - 19

## General Information

The following should be considered when reviewing this User Guide:

- Instructions are provided for the Xen digital telephones (DTU-type). When using a Ranger Series digital telephone (ETU-type), note that **ANS=Answer**, **TRF=Transfer**, **SPKR=Speaker**, **CNF=Conf**, **FNC=Feature**, **LNR/SPD=Redial**.
- All operational instructions assume Prime Line Pickup is assigned to intercom dial tone, Ringing Line Preference is assigned to all telephones, a Call Appearance and Call Arrival key has been assigned to all digital telephones and only a single tenant has been assigned in the system.
- All access codes listed are standard; some may vary based on system assignment. Please consult your authorised NEC Dealer for the access codes applicable to your system.
- Access to many features is based on system assignments. Not all features may be available from your telephone.
- Telephones equipped with displays will provide useful call processing information such as digits dialled, recall indications, feature confirmation, etc. Xen digital telephones (DTU-type) also show features accessible by the soft keys.

### LED Indications

Function	Lamp Status
<b>Line Keys:</b>	
Incoming Call	Rapid Flashing Red
Held Call - Your telephone	Slow Flashing Green
Held Call - Other telephone	Slow Flashing Red
Call in progress	
Your telephone	Steady Green
Other telephone	Steady Red
Hold recall	Intermittent Flashing Green
<b>Large LED: (360° Visual Ring Indicator)</b>	
Incoming calls (CO/PBX, DIT or ANA)	Rapid Flashing Green
Incoming intercom, TIE Line or DID Call	Rapid Flashing Red
Message from Attendant	Slow Flashing Green
Voice Mail Message	Slow Flashing Red
<b>Feature Key:</b>	
DND Set	Intermittent Flashing Red
Call Forward Set	Intermittent Flashing Red
Callback Request	Slow Flashing Red
<b>Intercom LED:</b>	
incoming Call	Flashing Red
Call in progress	Steady Red
Held Call	Flashing Red Conf LED

## Answering Calls

### Ringling Calls

- Lift Handset
- Converse

**Note:** When assigned the delayed ringing feature, incoming calls will first ring at a primary station. If the call is unanswered after a preprogrammed time interval, calls will also ring at the assigned secondary station.

### Ringling Calls To A Call Arrival Key

- Lift handset
- Converse

**Note 1:** A Call Arrival key must be assigned to appear and ring at a Line Key/Feature Access Key.

**Note 2:** A Call Appearance key must be available to answer an incoming outside call.

### Voice Announce Calls

- Ensure microphone (MIC) LED is lit
- Adjust Speaker volume ▲ or ▼ as needed
- Respond handsfree

**Note:** The handset may be used at any time during the conversation

### Camp-on (Call Waiting)

Receive camp-on tone while on another call

- Replace handset to disconnect present call OR press **Hold** and press the **Hookswitch** to converse with second party.

### Call Alert Notification

With a call in progress

- Receive Call Alert Notification
- Press **Hold**, converse with second party

**Note 1:** The second call may be placed on hold if the line appearance is assigned or if a Call Appearance key is available

**Note 2:** Press flashing Line Key, Call Appearance key or Conf key to return to the first call.

## Making Calls

### Internal Calls

- Lift handset
- Dial station number or "9" for the attendant (or reception)  
OR press **Feature Access Key** or **One Touch Key** programmed for Direct Station Selection
- Voice announce after tone burst or wait for ringing call to be answered.

**Note 1:** When calling a digital telephone, dialling 1 after the station number will change ringing to voice or voice to ringing.

**Note 2:** To directly access a personal voice mailbox on the Xen Mail system, dial 7 after dialling the station number.

### Outside Calls

- Lift handset
- Dial trunk access code i.e 0  
OR press idle **Outside Line Key**
- Dial telephone number
- Converse

### Preset Dialling

- Dial the desired number
- Lift handset
- Converse

### Last CO/PBX Number Redial

- Lift handset
- Press **Redial**
- Dial Last Number Redial code #
- Converse

### Speed Dial- Using The Redial (LNR/SPD) key

- Lift handset
- Press **Redial (LNR/SPD)** and dial Speed Dial Memory Location:  
Station Speed Dial 80-99  
System Speed Dial 00-79  
OR press **Feature Access key** or **One Touch Key** programmed for Station Speed Dial
- Converse

### Speed Dial - Using The Softkeys

- Press the **SYS.** or **STA.** Softkey (△)  
(System or Station Speed Dial respectively)

Continued next page

- Press the **UP** or **DOWN** softkey ( $\Delta$ ), repeatedly until the desired name/number is displayed.
- To search alphabetically (optional step):
  - Press the dial key showing the first letter of the name to be dialled
  - Continue to press this dial key until the desired letter is displayed
  - Press \* to display the first match corresponding the chosen letter
- Lift handset to dial the displayed name/number

### Trunk Queuing

After dialling trunk access code or pressing a busy **Line Key** and receiving a line busy indication:

- Dial Trunk Queue set code **78**
- Replace handset

**Note:** When a line is available, your telephone will ring: lift handset and place call.

## Microphone Control

- Press **Feature**
- Dial MIC On/Off code **1**

**Note 1:** Lit MIC LED indicates MIC on

**Note 2:** **MIC ON/OFF** key may be assigned to a Feature Access Key or One Touch Key

**Note 3:** If talking on handset rather than handsfree, the handset microphone will be muted and the MIC LED will flash.

## Handsfree Calls

- Press **Speaker**, LED lights
- Ensure **MIC LED** is lit
- Place internal or outside call
- Converse
- Press **Speaker** to disconnect call

**Note:** The handset may be used at any time during the conversation. To resume handsfree operation or to monitor a call, press **Speaker** (LED lights) and replace handset.

## Placing A Call On Hold

### Non-Exclusive Hold

With a call in progress:

- Press **Hold**

## Placing A Call On Hold (Continued)

### Exclusive Hold

With a call in progress:

- Press **Feature**
- Press **Hold**

**Note 1:** To retrieve a held call, press the flashing Line Key, Call Appearance Key or Conf key (for internal calls).

**Note 2:** Call on Non-Exclusive Hold can be retrieved from any digital telephone with the held line appearance or **Call Appearance key**.

**Note 3:** After a preprogrammed time, the held call will recall to the originating station. Once in a recall condition, Exclusively Held calls can be retrieved from any station with the held line appearance or **Call Appearance key**.

## Transferring Calls

### Using Manual Dial

With a call in progress

- Press **Transfer**
- Dial station number
- Announce call (optional)
- Replace handset

### Using Direct Station Selection (DSS)

With a call in progress

- Press **Transfer**
- Press programmed **DSS**
- Announce call (optional)
- Replace handset

**Note 1:** If the called station is busy, replace handset to initiate a camp-on. Unanswered camp-ons and unscreened transfers will recall to the attendant telephone. After answering the recall, pressing **Feature 86** will transfer the call to the personal voice mailbox of the station number dialled.

**Note 2:** To return to the original party, press flashing **Line Key, Call Appearance key or Conf key**.

**Note 3:** A **Feature Access Key** or **One Touch Key** may be assigned for DSS.

**Note 4:** To transfer a call directly to a personal voice mailbox, dial 7 after dialling the station number.

## Conference

With a call in progress

- Press **Conf**
- Place second call (internal or external)
- Announce conference
- Press **Conf** to establish conference

**Note 1:** Repeat above procedure to add an additional party. (Max 2 outside parties).

**Note 2:** An unsupervised conference may be established by pressing the Conf key again, after the conference has been established. The parties may continue to converse in private. Press the flashing Conf key to return to the conversation.

## Call Park - System

### Set

With a call in progress

- Press **Transfer**
- Dial Call Park Set code **4\***
- Dial Call Park location 0-9
- Replace handset

### Retrieve

From any station

- Lift handset
- Dial Call Park Retrieval code **4#**
- Dial Call Park Location 0-9
- Converse

**Note:** If the dialled Call Park location is busy, dial another Call Park location (0-9).

## Station Busy/No Answer Options

### Automatic Callback

#### Set

When calling a busy digital telephone

- Dial Automatic Callback code **0**
- Replace handset

#### Answer

When both telephones are idle originating telephone rings

- Lift handset
- Call is placed automatically

### Callback Request

#### Set

When calling a busy or unanswered digital telephone

- Dial Callback Request code **#**
- Replace Handset

#### Answer

Receive display and/or **Feature** LED message indication:

- Lift handset
- Dial **#**; request originator is automatically called
- Repeat above procedure to respond to additional messages

**Note:** Callback messages are automatically cancelled once the originating station is called.

### Tone Override

#### Set

When calling a busy digital telephone:

- Dial Tone Override code **\*** to send tone
- Wait for signalled party to answer

#### Answer

With a call in progress:

- Receive tone override signal†
- Press **Hold**
- Converse with second party

†If handsfree, a visual indication only (**\***) will be provided on the telephone's display.

**Note:** An Override Tone will be sent each time "**\***" is pressed.

## Station Busy/No Answer Options (Continued)

### Step Call

When calling a busy telephone

- Dial **2** to advance to the next station number in that 10's group

### Voice Over

#### Originate

When calling a busy telephone:

- Dial Voice Over code **6**
- Announce message

#### Answer

With a call in progress:

- Receive Voice Over announcement
- Press **Hold**
- Converse with Voice Over originator
- Press **Answer** key to alternate between parties

#### Whisper Page

With a call in progress:

- Receive Voice Over announcement
- Press **Feature**
- Dial **65**
- Converse with Voice Over originator while monitoring first call
- Press **Feature**
- Dial **65**
- Converse with first caller while monitoring Voice Over originator

**Note:** The Whisper Page Access Code may be assigned to a Feature Access Key or One Touch Key.

## Outside Call Dialling Options

### Save & Repeat

#### Save

With an originating outside call in progress:

- Press **Feature**
- Dial **9**; called number is stored
- Replace handset

#### Repeat

Lift handset

- Press **Redial**
- Dial **#**; stored number is dialled

## Outside Call Dialling Options (Continued)

### Store & Repeat

#### Store

With an outside call in progress:

- Press **Feature**
- Dial **7**
- Dial new phone number to be stored
- Press **Feature**
- Complete conversation and replace handset

#### Repeat

Lift handset

- Press **Redial**
- Dial **\***; stored number is dialled

**Note:** Store & Repeat and Save & Repeat features cannot be used simultaneously.

### Automatic Redial

After originating a busy or unanswered outside call:

- Press **Speaker**
- Replace handset
- Press **Feature**
- Press **Redial**
- Call is repeatedly dialled until answered, cancelled or the maximum number of redial attempts is reached
- Lift handset when the called party answers

**Note 1:** Press **Speaker** to cancel Automatic Redial.

**Note 2:** System programming determines waiting time and number of redial attempts.

### Caller ID

#### Answer

Receive incoming ringing or transferred outside call:

- Review telephone display for calling party's name or number
- Answer call accordingly

#### Placing Caller ID Calls

- Press **SCROLL** repeatedly until desired number is displayed
- Lift handset to automatically dial displayed number
- Converse

**Note 1:** Caller ID will be displayed even when station is busy or in DND mode, allowing the user to identify the incoming call.

**Note 2:** The last 10 calls received with caller ID information are stored and are accessible with the **SCROLL** key.

**Note 3:** Least Cost Routing (LCR) is required to automatically dial Caller ID calls.

**Note 4:** Press lit **Line Key** to review calling party's name or number while the call is in progress.

## Call Pick Up

### Call Pick Up System

Upon hearing ringing at another telephone:

- Lift handset
- Dial Call Pickup code:
  - All Calls 68
  - Outside Line 6\*
  - Night Call Pickup 69
- Converse

### Call Pick Up Direct

Upon hearing ringing or voice announcement at another telephone:

- Lift handset
- Dial Call Pickup Direct code 67
- Dial station number of the telephone to be answered
- Converse

## Paging

- Lift handset
- Dial paging code:

### Internal

- -All zones 51
- -Zone A 52
- -Zone B 53
- -Zone C 54

### External

- -All int. & ext. 59
- -All zones 55
- -Zone A 56
- -Zone B 57
- -Zone C 58

- Page
- Wait for Meet-Me Answer or replace handset

### Meet-Me Answer

- Lift handset
- Dial Meet-Me Answer code:
  - Internal Page 5\*
  - External Page 5 #
- Converse

## Background Music

### Set/Cancel

- Press Feature
- Dial BGM On/Off code 26

**Note:** A BGM key may be assigned in system programming to set/cancel the Background Music feature.

## Call Forward All Calls (CF/A) Do Not Disturb (DND)

### Set

- Press **Feature**
- Dial Call Forward All/DND  
set code **60**
- Select operation
  - DND**: Press **Feature**
  - Call Forward All**: Dial  
destination station number or  
voice mail and press **Feature**

### Cancel

- Press **Feature**
- Dial Call Forward All/DND  
cancel code **69**
- Press **Feature**

**Note 1:** The **Feature** LED will flash intermittently when your telephone is in **Call Forward/DND**.

**Note 2:** While set, Call Forward All will override Call Forward Busy/No Answer setting.

**Note 3:** If Call Forward All and Do Not Disturb are both set, the feature set last is activated.

**Note 4:** A **CFA/DND** key may be assigned in system programming to set/cancel this feature. When setting Call Forward All, a destination station must be entered. A lit LED indicates that Call Forward All/Do Not Disturb is set.

## Call Forward Busy/No Answer (B/NA)

### Set

- Press **Speaker**
- Dial Call Forward B/NA  
set code **43**
- Dial destination station number  
or voice mail
- Press **Speaker**

### Cancel

- Press **Speaker**
- Dial Call Forward cancel code **44**
- Press **Speaker**

**Note 1:** The **Feature** LED will flash intermittently when your telephone is in **Call Forward**.

**Note 2:** While set, Call Forward All will override Call Forward Busy/No Answer setting.

**Note 3:** A **CF B/NA** key may be assigned in system programming to set/cancel this feature. When setting Call Forward Busy/No Answer, a destination station must be entered. A lit LED indicates that CF B/NA is set.

## Call Forward Destination

### From Destination Station

#### Set

- Press **Speaker**
- Dial Call Forward All Destination set code **47**
- Dial your station number
- Dial destination station number or voice mail
- Press **Speaker**

#### Cancel

- Press **Speaker**
- Dial Call Forward All Destination cancel code **48**
- Dial your station number
- Press **Speaker**

## Customised Message

From display telephone:

- Press **Feature**
- Dial Customised Message code **70**
- Dial \* to scroll through messages
- Dial # to select messages
- Dial return date and time if required (Month/Day, Hour/Minute, using 4-digit, 24 hour clock)
- Press **Feature**

**Note:** When your telephone is set for **Do Not Disturb**, other display telephones will receive your message upon calling your station.

## Station Outgoing Lockout

### Changing Lockout Code

- Press **Speaker**
- Dial Lockout Change access code \_\_\_\_\_
- Dial current Lockout code
- Dial new Lockout code
- Press **Speaker**

**Note 1:** By default, Lockout code is set at 00000000 (10 zeros).

**Note 2:** When Lockout code is set for the first time, station is automatically restricted.

**Note 3:** Lockout code may be a maximum of 10 digits. If the new Lockout code is less than 10 digits, press the Speaker to re-enter.

**Note 4:** When set, Station Outgoing Lockout restricts all outgoing calls.

## Set/Cancel Station Outgoing Lockout

- Press **Speaker**
- Dial Station Lockout
  - Set code \_\_\_\_\_
  - Cancel code \_\_\_\_\_
- Dial Lockout code
- Press **Speaker**

## Account Code Entry

- |  |  |
|--|--|
| With an outside call in progress           | With an outside call on hold:              |
| ■ Press <b>Feature</b>                     | ■ Dial Account Code Entry                  |
| ■ Dial <b>66</b>                           | Code_____                                  |
| ■ Dial Account Code<br>(16 digits maximum) | ■ Dial Account Code<br>(16 digits maximum) |
| ■ Press <b>Feature</b>                     | ■ Retrieve held call                       |

**Note 1:** The outside party will not hear digits being dialed.

**Note 2:** The Account Code Entry Code may be assigned to a **Feature Access Key** or **One Touch Key**.

## Account Code Forced/Verified

- To place an outside call:
- Lift handset
  - Dial Forced Account access code\_\_\_\_\_
  - Dial Forced Account code\_\_\_\_\_(up to 13 digits)
  - Dial trunk access code i.e. 0 and outside number

**Note:** When calling from a station that is assigned the Account Code Forced/Verified feature, outgoing call will only be processed after the dialled Account Code is verified.

## DISA Password

### Setting Your DISA Password

- Lift handset
- Dial DISA Password set access code\_\_\_\_
- Dial your DISA ID code\_\_\_\_
- Dial your current DISA password\_\_\_\_ default 000000000 (10 zeros)
- Dial your new DISA password\_\_\_\_
- Replace handset

**Note 1:** Password may be a maximum of 10 digits. If the new password is less than 10 digits, replace the handset to enter.

**Note 2:** It is recommended that your DISA password be 10 digits and be changed frequently to prevent unauthorised use.

## ACD/UCD

### Log On

- Press **Speaker**
- Dial access code\_\_\_\_
- Dial 1
- Press **Speaker**

### Log Off

- Press **Speaker**
- Dial access code\_\_\_\_
- Dial 2
- Press **Speaker**

**Note:** A LOG key may be assigned in system programming to log/off from the ACD/UCD group. A lit led indicates that the station is logged-on.

## Break Mode

### Set

- Press **Speaker**
- Dial 40
- Press **Speaker**

### Cancel

- Press **Speaker**
- Dial 42
- Press **Speaker**

**Note 1:** Break Mode is only available while an agent is logged-on.

**Note 2:** A Break key may be assigned in system programming to set/cancel Break Mode. A lit LED indicates that the station is in Break Mode.

## Answering Call Using Headset

- Press **HEADSET** to answer
- Converse
- Press **HEADSET** to hang up

## Volume Control

### Off-Hook Ringing Volume

- Lift handset
- Dial **60**
- Dial Off-Hook Ringing
- Volume code **r**
- Press **▲** or **▼** to set level
- Replace handset

### Ringling Volume

- Press Speaker
- Dial **60**
- Dial Ringing Volume code **r**
- Press **▲** or **▼** to set level
- Press Speaker

**Note 1:** Press **▲** or **▼** during audible telephone activity to adjust handset or speaker volume.

**Note 2:** When the telephone is idle, **▲** or **▼** is used to adjust display contrast.

## Programming

### Resetting Feature LED

- Press **Feature**
- Dial **99**
- Press **Feature**

**Note:** Resetting the **Feature** LED will cancel Call Forward All Calls, Do Not Disturb and Callback Request settings.

### Station Speed Dial - Dial Access

- Press **Feature**
- Press **Redial**
- Dial Speed Dial Memory location **80-99**
- Dial trunk access code i.e. **0** (if necessary)
- Dial telephone number to be stored (24 digits maximum)
- Press **Hold** (if entering name) and dial name of party (13 letters maximum)
- Press **Feature**

**Note 1:** Press **Redial** to insert a pause or **Recall** to store a hookflash.

**Note 2:** Refer to **Character Entry Codes** when entering name of party.

**Note 3:** Station Speed Dial is not available when 1000 System Speed Dial mode is selected.

## Feature Access Keys

### Station Speed Dial (Outside Numbers)

- Press **Feature**
- Press **Redial**
- Press **Feature Access Key** to be programmed
- Dial **o**
- Dial trunk access code i.e **o** (if necessary)
- Dial telephone number to be stored (16 digits maximum)
- Press **Feature**

### DSS/BLF (Stations) And Feature Access

- Press **Feature**
- Press **Redial**
- Press **Feature Access Key** to be programmed
- Dial **r** and station number to be stored
- OR dial feature access code to be stored as indicated in the **Quick Entry Guide**
- Press **Feature**

**Note 1:** Press **Redial** to insert a pause and **Recall** to insert a hookflash.

**Note 2:** Busy Lamp Field status indication will be provided on keys programmed for DSS.

## One Touch Keys

### Station Speed Dial (Outside Numbers)

- Press **Feature**
- Press **Redial**
- Press **One Touch Key** to be programmed
- Dial **o**
- Dial trunk access code i.e **o** (if necessary)
- Dial telephone number to be stored (16 digits maximum)
- Press **Feature**

### DSS/BLF (Stations) And Feature Access

- Press **Feature**
- Press **Redial**
- Press **One Touch Key** to be programmed
- Dial **r** and station number to be stored
- OR dial feature access code to be stored as indicated in the **Quick Entry Guide**
- Press **Feature**

**Note 1:** Press **Redial** to insert a pause and **Recall** to insert a hookflash.

**Note 2:** Busy Lamp Field status indication will be provided on keys programmed for DSS.

## Character Entry Codes

Character	Code	Character	Code	Character	Code
Blank	032	@	064		096
!	033	A	065	a	097
	034	B	066	b	098
#	035	C	067	c	099
\$	036	D	068	d	100
%	037	E	069	e	101
&	038	F	070	f	102
'	039	G	071	g	103
(	040	H	072	h	104
)	041	I	073	i	105
*	042	J	074	j	106
+	043	K	075	k	107
,	044	L	076	l	108
-	045	M	077	m	109
.	046	N	078	n	110
/	047	O	079	o	111
0	048	P	080	p	112
1	049	Q	081	q	113
2	050	R	082	r	114
3	051	S	083	s	115
4	052	T	084	t	116
5	053	U	085	u	117
6	054	V	086	v	118
7	055	W	087	w	119
8	056	X	088	x	120
9	057	Y	089	y	121
:	058	Z	090	z	122
;	059	[	091	{	123
"	060	\	092		124
=	061	]	093	}	125
"	062		094	→	126
?	063	_	095		127

## Quick Entry Guide For Programming Feature Access Keys and One Touch Keys

Feature	Press
Microphone On/Off	# > 1
Call Forward All Set	# > 60 > Dial destination > Answer > Feature (FNC) > Feature (FNC)
Do Not Disturb - Set	# > 60 > Answer > Feature (FNC) > Feature (FNC)
Call Forward All/DND - Cancel	# > 69 > Answer > Feature (FNC) > Feature (FNC)
Save & Repeat - Set	# > 9
Store & Repeat - Set	# > 7
Whisper Page	# > 65
Quick Transfer To Voice Mail	# > 86
Background Music	# > 26
Voice Over Originate	1 > 6
Call Forward Busy/ No Answer - Set	1 > 43 > Dial Destination > Answer > Speaker > Feature (FNC)
Internal Paging All Zone	1 > 51
Internal Paging Meet-Me	1 > 5*
External Paging All Zone	1 > 55
External Paging Meet-Me	1 > 5#
Call Pick Up All Calls	1 > 68
Call Pick Up Direct	1 > 67

**Note 1:** When pressed, the Answer Key will not appear in the display. This is normal operation.

**Note 2:** Other features may be programmed in addition to those listed above. Refer to the Xen Mail User Guide for features related to Voice Mail.

## Quick Reference Guide

### Outside Calling

Outside Call	Dial 0 > Dial Telephone Number
Last CO/PBX number redial	Redial > Dial #
Speed Dial	Redial > Dial 00-99
Save/Store & Repeat - Access	Redial > Dial *
Trunk Queue	Receive Trunk Busy Indication > Dial 78
Automatic Redial	Receive busy > Speaker > Replace Handset > Feature > Redial

### Internal Calling

Station Call	Dial Station Number or DSS key
Automatic Callback	Reach Busy Station > Dial 0
Callback Request	Reach Busy/No Answer Station > Dial #
Tone Override	Reach Busy Station > Dial *
Voice Over Originate	Reach Busy Station > Dial 6
Quick Transfer To Voice Mail	Dial station number or DSS key > Dial 7

### With A Call In Progress

Hold	Hold
Exclusive Hold	Feature > Hold
Transfer	Transfer > Dial Station Number or DSS key
Quick Transfer To Voice Mail	Transfer > Dial Station Number or DSS key > dial 7
Conference	Conf > Place 2nd Call > Conf
Call Park System	SET: Transfer > Dial 4* > Dial 0 - 9 RETRIEVE: Dial 4 # > Dial 0 - 9
Save & Repeat - Save	Feature > Dial 9
Store & Repeat - Store	Feature Dial 7 > Dial number to Store > Feature
Whisper Page	Receive Voice Over > Feature > Dial 65

### From The Intercom

Internal Paging	Dial 51-54 > Page
External Paging	Dial 55-59 > Page
Call Pickup All Calls	Dial 68
Call Pickup Direct	Dial 67 > Dial Station Number

### From An Idle Telephone

Microphone Control	Feature > Dial 1
Call Forward All/DND	SET: Feature > Dial 60 > Dial Destination Station (CF/A Only) > Feature CANCEL: Feature > Dial 69 > Feature
Call Forward Busy/No Answer	SET: Speaker > Dial 43 > Dial Destination Station > Speaker CANCEL: Speaker > Dial 44 > Speaker
FNC LED Reset	Feature > Dial 99 > Feature

## Notes





**NEC**

This material contained herein is subject to change without  
prior notice at the sole discretion of NEC Australia Pty Ltd.

VERSION 1 5/99 DOCUMENT NO. A6-324000-642-17 COPYRIGHT © 1999 NEC AUSTRALIA